

HELICOPTERS	AgustaWestland _BAAC
ELECTRONICS FOR DEFENCE AND SECURITY	SELEX Communications SELEX GALILEO SELEX Sistemi Integrati DRS Technologies Elsag Datamat SELEX Service Management Seicos VEGA
AERONAUTICS	Alenia Aeronautica AleniaNorthAmerica Alenia Hellas Alenia Aeromacchi Alenia Aeronavali SuperJet International Alenia Composite AleniaSIA Quadrics ATR _Global Military Aircraft Systems _Global Aeronautica
SPACE	Telespazio _Thales Alenia Space
DEFENCE SYSTEMS	Oto Melara WASS _MBDA
ENERGY/ TRANSPORTATION	Ansaldo Energia AnsaldoFuelCells Ansaldo Nucleare Ansaldo Ricerche AnsaldoBreda Ansaldo STS BredaMenarinibus

Finmeccanica
Piazza Monte Grappa, 4
00195 Rome - Italy
tel. +39 06 324731
fax +39 06 3208621
www.finmeccanica.com

AgustaWestland
Via Giovanni Agusta, 520
21017 Cascina Costa
di Samarate (Varese) - Italy
tel. +39 0331 229111
fax +39 0331 229605
www.agustawestland.com

Alenia Aeronautica
Via Campania, 45
00187 Rome - Italy
tel. +39 06 420881
fax +39 06 42824528
www.alenia-aeronautica.it

DRS Technologies
5 Sylvan Way
Parsippany, NJ 07054
tel. +1 973 8981500
fax +1 973 8984730
info@drs.com

SELEX Communications
Via Pieragostini, 80
16151 Genoa - Italy
tel. +39 010 6144000
fax +39 010 60935796
www.selex-comms.com

SELEX GALILEO
- Galileo Avionica
Via Albert Einstein, 35
50013 Campi Bisenzio (FI) - Italy
tel. +39 055 89501
fax +39 055 8950600
www.selexgalileo.com

- SELEX Sensors and Airborne Systems
Christopher Martin Road,
Basilton, Essex SS14 3EL - UK
tel. +44 1268 522822
fax +44 1268 883140
www.selexgalileo.com

WASS
Via di Levante, 48
57128 Livorno - Italy
tel. +39 0586 840111
fax. +39 0586 854060
www.whiteheadaleniasistemi.subacquei.com



BANGALORE AIR FORCE STATION YELAHANKA
11th - 15th February 2009



ASIA'S PREMIER AIR SHOW
AERO INDIA 2009

AgustaWestland, Alenia Aeronautica, DRS Technologies,
SELEX Communications, SELEX GALILEO, WASS

FINMECCANICA TODAY

Finmeccanica is the main Italian industrial group operating globally in the aerospace, defence and security sectors, and is one of the world's leading groups in the fields of helicopters and defence electronics. It is also the European leader for satellite and space services as well as having considerable know-how and production capacity in the energy and transport fields. Headquartered in Italy and with a vast industrial base in the UK as well as important production facilities in the rest of Europe and in the USA, Finmeccanica has a workforce of more than 70,000 people, and a revenues volume of euro mil. 13,429.

Technology and innovation are the keystones of Finmeccanica's success and competitive edge. For this reason, the Group invests 1,836 billion euros a year in R&D activities, making Finmeccanica the leading Italian investor in hi-tech sectors. As far as the core business is concerned, investments amount to 20% of turnover - a percentage that is higher than some of its main competitors. A large part of R&D investment is channelled into dual technology projects, leading to significant advantages in civil applications of considerable strategic importance. To maintain its leadership in hi-tech sectors, Finmeccanica focuses on the value of its human resources, and the laboratories of its subsidiaries are staffed by around 3,000 highly specialized researchers.

WASS
A244/S Mod.3 lightweight Torpedo

PRODUCTS ON DISPLAY



AgustaWestland
AW119 Ke
AW109 Power Coast Guard
AW139 Coast Guard
NH90 NFH
AW101 VVIP
AW101 Mk3

SELEX GALILEO
ATOS LW
Mirach
Viglix
SLX
SEER
FOTRD
MLRD
PicoSAR
Seaspray 7000E
SLX Hawk
Vixen 850E
HIDAS

Alenia Aeronautica
ATR 72 ASW
ATR 72-600
C-27J
EFA
MOLYNX
SKY-Y

DRS Technologies
RVS-330
MRT
RBM
ARMOR X10
ARMOR C12

FINMECCANICA Stand C-24

SELEX Communications
LOAM
SWave Vehicular Radio
ANV-353
M-424
AS-300
SRT-170
SRT-651
Guardian
ADSB 1090 Ground Station

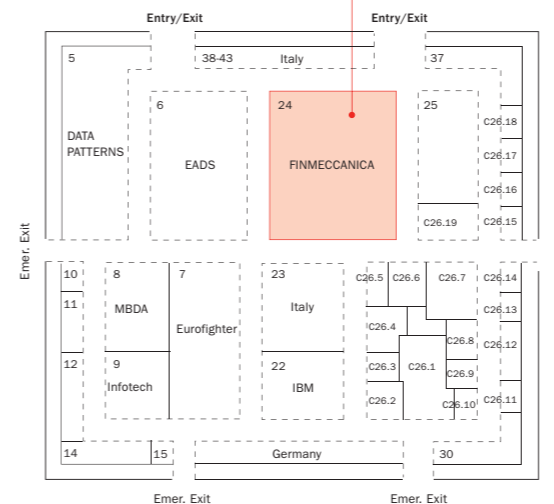

FINMECCANICA IN INDIA

Finmeccanica is increasing its international presence with a particular focus on India where the Group is promoting its most important platforms and systems, as well as enlarging the company's industrial and technological footprint via successful collaborations established with PSUs and private companies.

AgustaWestland, is present in India since the 1970's with the Sea King and commercial helicopter (AW 139 and AW 109). The company is a front runner in the major programs in the country. Industrial cooperation is a key element of its presence in India.

Alenia Aeronautica is promoting the C-27J, the most advanced medium transport aircraft. Engineering and tooling activities have been transferred to primary Indian companies.

SELEX Sistemi Integrati has a leading position in Air Traffic Management Systems, with a long standing collaboration with BEL. Selex Sistemi Integrati is promoting its key capabilities (C4I, VTMS, Naval Combat Systems, Coastal protection, Homeland Security and Radars).

DRS is a US company recently acquired by Finmeccanica. Its ruggedized processing and display devices and technologies, considered the best available in the market, are being proposed to the Indian forces for Battle Management and C4I Systems.

SELEX Communications has long term relations with all the military services. The company is promoting the Tactical Communication Systems and TETRA applications. Collaborations with BEL and other Indian industries have been in place for years now.

SELEX GALILEO is promoting aircraft electronically scanned radar sensors, electronic warfare systems, target drones, fire control systems for Air, Naval and Land applications. SELEX GALILEO has been present in India since many years.

Oto Melara is present in India since the 1990's with the 76 mm Naval Gun, produced under license by BHEL. The company is promoting the 127 mm naval gun representing the state-of-the-art large calibre naval gun.

WASS is involved in several underwater programs with the Indian Navy, in particular with its Black Shark heavy weight torpedo and torpedoes countermeasures. WASS has been present in the country since the 1970's with its light weight torpedoes A244S.

Elsag Datamat, has recently started to market solutions for law enforcement applications in India. Its unique plate reader systems as well as mobile check points and other worldwide leading technologies are under evaluation by the Indian Police Forces.

Finmeccanica
Piazza Monte Grappa, 4
00195 Rome - Italy
tel. +39 06 324731
fax +39 06 3208621

www.finmeccanica.com

AgustaWestland
Via Giovanni Agusta, 520
21017 Cascina Costa
di Samarate (Varese) - Italy
tel. +39 0331 229111
fax +39 0331 229605
www.agustawestland.com

Alenia Aeronautica
Via Campania, 45
00187 Rome - Italy
tel. +39 06 420881
fax +39 06 42824528
www.alenia-aeronautica.it

DRS Technologies
5 Sylvan Way
Parsippany, NJ 07054
tel. +1 973 8981500
fax +1 973 8984730
info@drs.com

SELEX Communications
Via Pieragostini, 80
16151 Genoa - Italy
tel. +39 010 6144000
fax +39 010 60935796
www.selex-comms.com

SELEX GALILEO
- Galileo Avionica
Via Albert Einstein, 35
50013 Campi Bisenzio (FI) - Italy
tel. +39 055 89501
fax +39 055 8950600
www.selexgalileo.com

- **SELEX Sensors and Airborne Systems**
Christopher Martin Road,
Basilidon, Essex SS14 3EL - UK
tel. +44 1268 522822
fax +44 1268 883140
www.selexgalileo.com

WASS
Via di Levante, 48
57128 Livorno - Italy
tel. +39 0586 840111
fax. +39 0586 854060
www.whiteheadaleniasistemi
subacquei.com



BANGALORE_AIR FORCE STATION YELAHANKA
11th - 15th February 2009



ASIA'S PREMIER AIR SHOW
AERO INDIA 2009

AgustaWestland, Alenia Aeronautica, DRS Technologies,
SELEX Communications, SELEX GALILEO, WASS

FINMECCANICA TODAY

Finmeccanica is the main Italian industrial group operating globally in the aerospace, defence and security sectors, and is one of the world's leading groups in the fields of helicopters and defence electronics. It is also the European leader for satellite and space services as well as having considerable know-how and production capacity in the energy and transport fields. Headquartered in Italy and with a vast industrial base in the UK as well as important production facilities in the rest of Europe and in the USA, Finmeccanica has a workforce of more than 70,000 people, and a revenues volume of euro mil. 13,429.

Technology and innovation are the keystones of Finmeccanica's success and competitive edge. For this reason, the Group invests 1,836 billion euros a year in R&D activities, making Finmeccanica the leading Italian investor in hi-tech sectors. As far as the core business is concerned, investments amount to 20% of turnover - a percentage that is higher than some of its main competitors. A large part of R&D investment is channelled into dual technology projects, leading to significant advantages in civil applications of considerable strategic importance. To maintain its leadership in hi-tech sectors, Finmeccanica focuses on the value of its human resources, and the laboratories of its subsidiaries are staffed by around 3,000 highly specialized researchers.

WASS

A244/S Mod.3 lightweight Torpedo

PRODUCTS ON DISPLAY



AgustaWestland

AW119 Ke
AW109 Power Coast Guard
AW139 Coast Guard
NH90 NFH
AW101 VVIP
AW101 Mk3

SELEX GALILEO

ATOS LW	MLRD
Mirach	PicoSAR
Vigilx	Seaspray 7000E
SLX	SLX Hawk
SEER	Vixen 850E
FOTRD	HIDAS

Alenia Aeronautica

ATR 72 ASW
ATR 72-600
C-27J
EFA
MOLYNX
SKY-Y

DRS Technologies

RVS-330
MRT
RBM
ARMOR X10
ARMOR C12

FINMECCANICA Stand C-24

SELEX Communications

LOAM
SWave Vehicular Radio
ANV-353
M-424
AS-300
SRT-170
SRT-651
Guardian
ADSB 1090 Ground Station

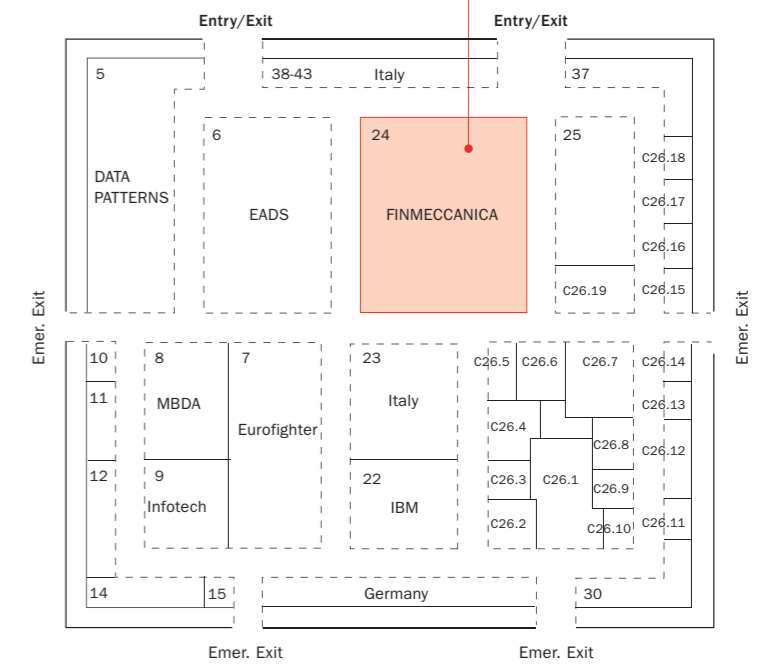

FINMECCANICA IN INDIA

Finmeccanica is increasing its international presence with a particular focus on India where the Group is promoting its most important platforms and systems, as well as enlarging the company's industrial and technological footprint via successful collaborations established with PSUs and private companies.

AgustaWestland, is present in India since the 1970's with the Sea King and commercial helicopter (AW 139 and AW 109). The company is a front runner in the major programs in the country. Industrial cooperation is a key element of its presence in India.

Alenia Aeronautica is promoting the C-27J, the most advanced medium transport aircraft. Engineering and tooling activities have been transferred to primary Indian companies.

SELEX Sistemi Integrati has a leading position in Air Traffic Management Systems, with a long standing collaboration with BEL. Selex Sistemi Integrati is promoting its key capabilities (C4I, VTMS, Naval Combat Systems, Coastal protection, Homeland Security and Radars).

DRS is a US company recently acquired by Finmeccanica. Its ruggedized processing and display devices and technologies, considered the best available in the market, are being proposed to the Indian forces for Battle Management and C4I Systems.

SELEX Communications has long term relations with all the military services. The company is promoting the Tactical Communication Systems and TETRA applications. Collaborations with BEL and other Indian industries have been in place for years now.

SELEX GALILEO is promoting aircraft electronically scanned radar sensors, electronic warfare systems, target drones, fire control systems for Air, Naval and Land applications. SELEX GALILEO has been present in India since many years.

Oto Melara is present in India since the 1990's with the 76 mm Naval Gun, produced under license by BHEL. The company is promoting the 127 mm naval gun representing the state-of-the-art large calibre naval gun.

WASS is involved in several underwater programs with the Indian Navy, in particular with its Black Shark heavy weight torpedo and torpedoes countermeasures. WASS has been present in the country since the 1970's with its light weight torpedoes A244S.

Elsag Datamat, has recently started to market solutions for law enforcement applications in India. Its unique plate reader systems as well as mobile check points and other worldwide leading technologies are under evaluation by the Indian Police Forces.

THE GROUP

Owned Companies _Joint Ventures

HELICOPTERS	AgustaWestland _BAAC
ELECTRONICS FOR DEFENCE AND SECURITY	SELEX Communications SELEX GALILEO SELEX Sistemi Integrati DRS Technologies Elsag Datamat SELEX Service Management Seicos VEGA
AERONAUTICS	Alenia Aeronautica AleniaNorthAmerica Alenia Hellas Alenia Aermacchi Alenia Aeronavali SuperJet International Alenia Composite AleniaSIA Quadrics _ATR _Global Military Aircraft Systems _Global Aeronautica
SPACE	Telespazio _Thales Alenia Space
DEFENCE SYSTEMS	Oto Melara WASS _MBDA
ENERGY/ TRANSPORTATION	Ansaldo Energia AnsaldoFuelCells Ansaldo Nucleare Ansaldo Ricerche AnsaldoBreda Ansaldo STS BredaMenarinibus